



**Electricity
Fundamentals**

Objective

- Become familiar with

Need edits/formatting

Introduction to Electricity

Atomic theory of matter and electricity

- Atom components:
 - Nucleus:
 - Protons – positively charged
 - Neutrons – no charge
 - Electrons – negatively charged
- Usually atoms have equal number of protons & electrons
- Gaining or losing an electron “charges” an atom – negatively or positively
- Metals have electrons that can easily be “knocked out of orbit” around the nucleus – these free electrons and the materials are conductors
- When atom loses electrons, it contains a + charge; the atom can easily attract and acquire additional electrons, making it negatively charged
- Alternating state of positively and negatively charged particles permits flow of electrons between the two atoms
- Flow of electrons is electrical energy - electricity

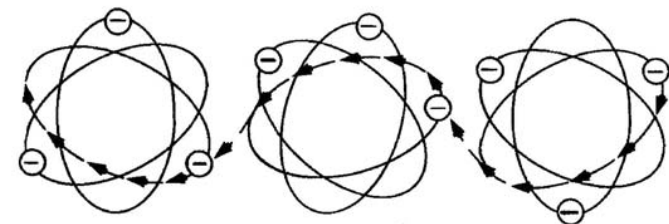
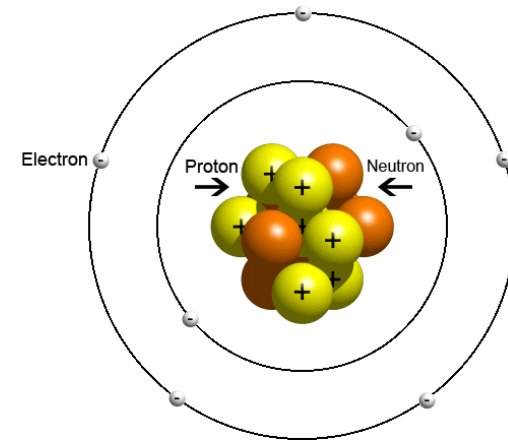

Introduction to Electricity

Production of electricity - chemical

- Batteries produce flow of electrons by chemical reaction between two electrodes
 - Electrodes – “solid conductors through which an electric current can pass”
 - One electrode give up electrons; the other collects them
- Electrodes constructed of dissimilar metals
- When encased in an electrolyte (e.g., acid or paste), electricity is produced by chemical reactions of electrolyte & conductors
- Batteries produce Direct Current (DC) – electron flow in one direction only



Introduction to Electricity

Production of electricity – magnetic induction/magnetism

- Most widely used form of electricity generation
- Rotating magnets within a coil of wire create lines of force that cause an alternating current (AC) to flow within the wire
- Magnets break lines of force and induce AC to be produced
- This method of electrical generation powers our homes, offices, and HVAC equipment

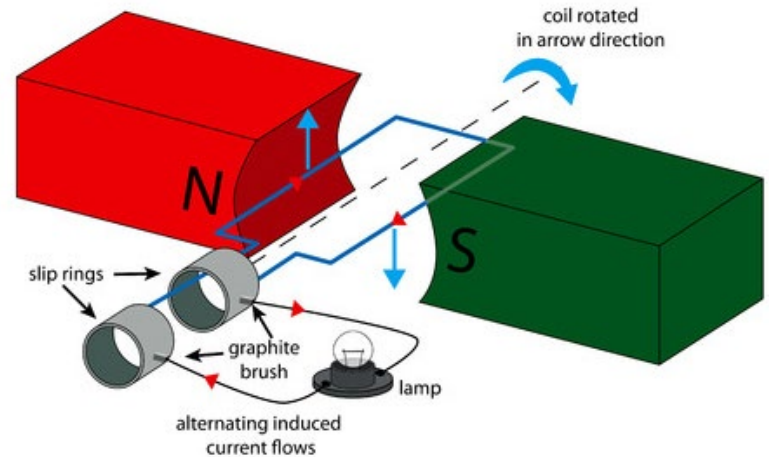

Introduction to Electricity

Production of electricity – heat

- Small amount of voltage is produced if two dissimilar metals are joined together at one end and the junction is heated
- Example: Heat from pilot flame causes thermocouple to create small amount of DC voltage.
 - Voltage energizes small coil in gas valve, holding pilot valve open to allow gas to flow
 - If flame goes out, heat is removed from thermocouple, causing pilot valve to close

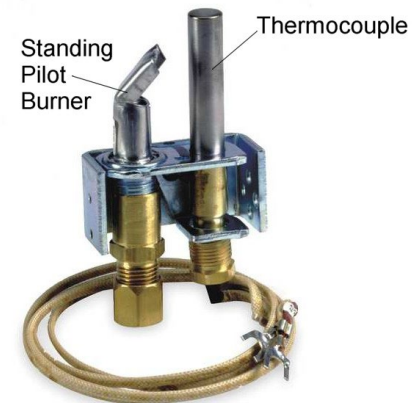
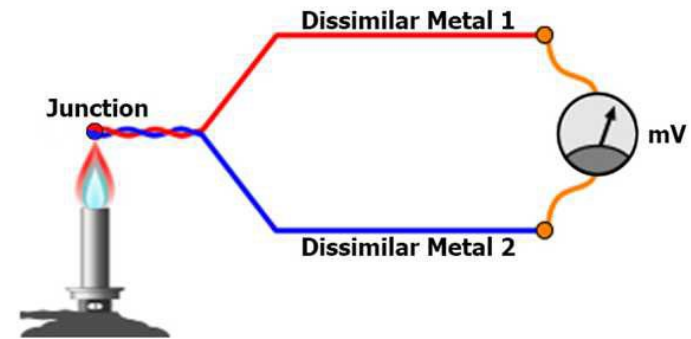

Introduction to Electricity

Conductors and insulators of electricity

Conductors

- Not all metals conduct electricity equally
- Good electrical conductors:
 - Copper
 - Aluminum
 - Silver

Insulators do not easily give up or take on free electrons

- Examples:
 - Glass
 - Rubber
- Insulators can fail if:
 - Electrical potential exceeds insulating characteristics
 - Amount of current exceeds rating of the conductor

Good conductors & insulators are necessary for operation & control of HVAC components

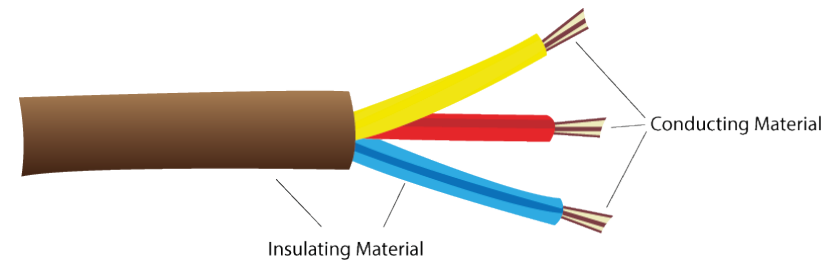

Introduction to Electricity

Electrical potential (Voltage)

- Voltage (represented by "E") is the **pressure** behind electron flow
- Volt measures pressure of electricity
 - Does not indicate total amount of energy being used
 - Just as with a water pipe, there can be pressure without flow when it is turned off
- Drop in pressure occurs when demand of usage exceeds capabilities of incoming supply
 - Example: When a large load starts, lights dim for a second
 - Voltage drops when this occurs
- Systems that run on higher voltage have capability of using more total energy, but usage is determined by the load doing the work

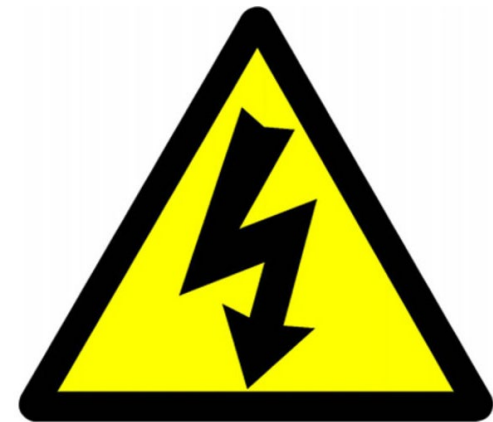

Introduction to Electricity

Current flow (Amperage)

- Amperage (represented by "I") is the **flow of electrons**: current
- For current to flow, must be a complete path from the power source to the load and back
 - Pathway is called a circuit
- Two types of current:
 - Direct Current (DC) – flow of electrons in one direction
 - Alternating Current (AC) – flows in two directions (change in direction is called frequency, measured in hertz)
- Current is measure in amperes (represented by symbol "A")
 - 1 microamp (μ) = 0.000001
 - 1 milliampere (m) = 0.001
 - 1 kiloamp (k) = 1000

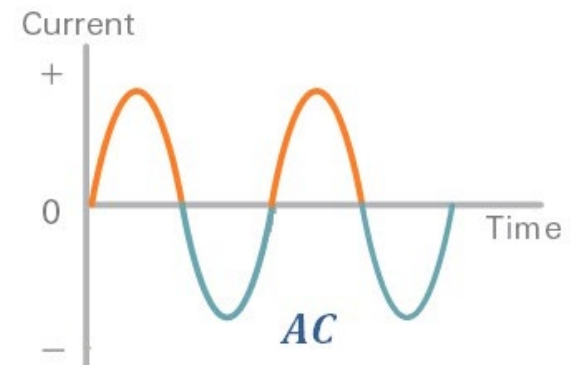
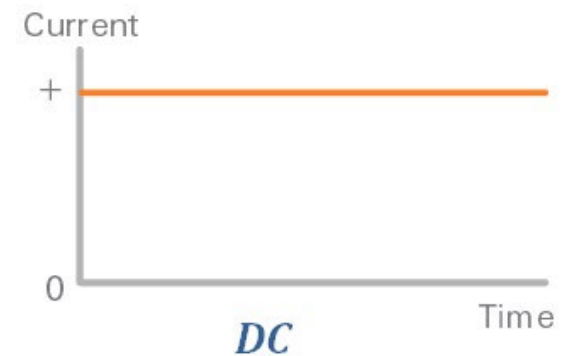

Introduction to Electricity

Resistance (opposition to current flow)

- Resistance (represented by “R”) is the **opposition to current flow** – measured by the Ohm (Ω).
- There is some resistance in conductors of electricity
 - Example: If you run extension cord down street, there will be voltage drop when you energize a large load, due to resistance in the wire
- As long as the pathway (wire) is sized correctly, there should only be minimal voltage drop

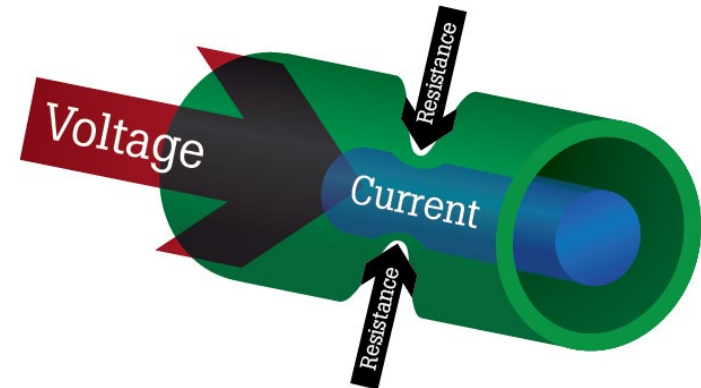

Introduction to Electricity

Wattage (electric power)

- Wattage (represented by “W” or “P”) is the measurement of **electric power** – the rate at which electrons do work
- One watt = power generated by one ampere of current driven by one volt
- Total power consumed is measured by the watt
- Electricity is sold by kilowatt hour (1000 watts)
- Two formulas to remember:
 - 1 Watt = 3.413 BTUhs of heat
 - 1 Horsepower = 746 watts

Introduction to Electricity

Ohm's Law

- Ohm's Law = mathematical relationship between voltage, current, and resistance
- Key to using Ohm's Law is knowing any two of the three

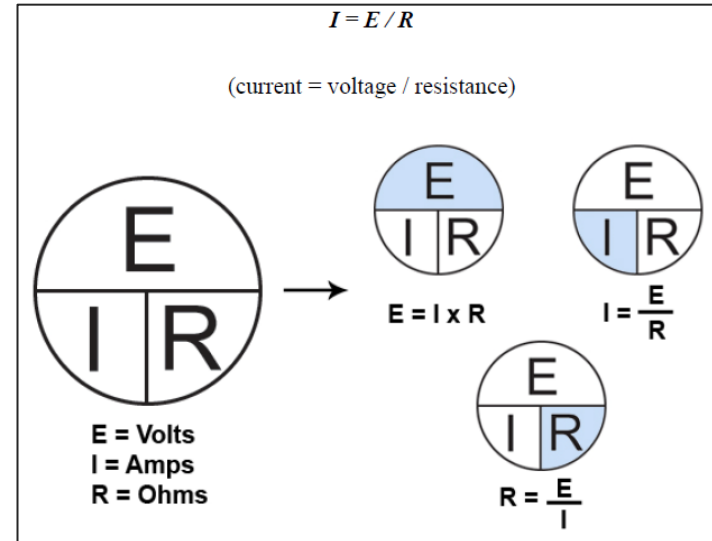

Example:

What is the current in the depicted circuit?

- 1) When finding current use: $I = E / R$
- 2) Determine the applied voltage from the diagram.
- 3) Determine the resistance of the single resistor load in the circuit.
- 4) Divide voltage by resistance using the formula. $I = 120 / 40$
- 5) The answer is: $I = 3 \text{ amps}$



Introduction to Electricity

Watt's Law

- Electric power (watts) can be calculated using Watt's Law
 - $P = I \times E$
- Determine wattage by measuring current in the circuit and applied line voltage
- Two additional formulas use reciprocals to calculate electric power:
 - $P = E^2 / R$
 - $P = I^2 \times R$

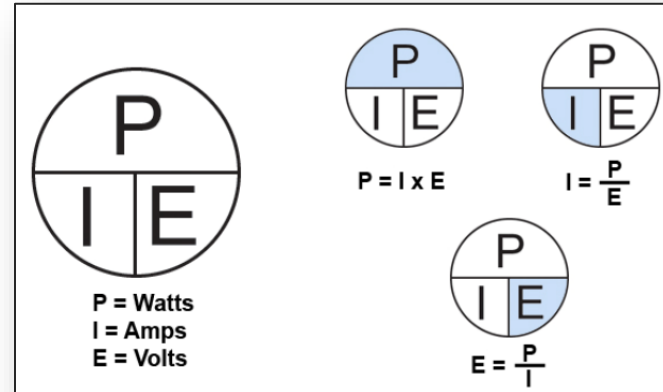

How many amperes of current will be measured on a 5000-watt element with 240 VAC applied?

Example:

- 1) When solving for current, you choose: $I = P / E$
- 2) Take the 5000 watts and divide it by 240 volts: $5000 / 240$
- 3) The answer is: $I = 20.83$ amperes

Electrical Circuits

Introduction to circuits

- **Series circuits** – only one path for current to flow
- **Parallel circuits** – more than one path for current to flow; each branch receives source voltage
- **Series-parallel circuits** – combine the two types; usually comprised of a switch or switches wired in series with two or more parallel circuits

Series Circuit

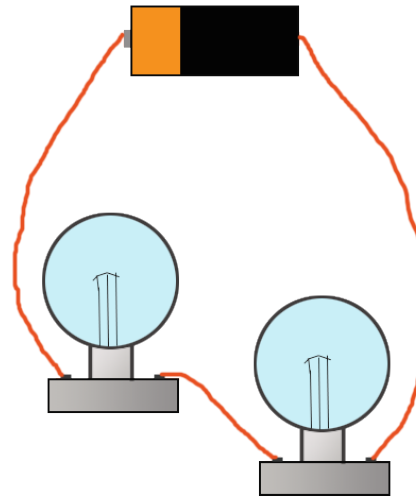

Parallel Circuit

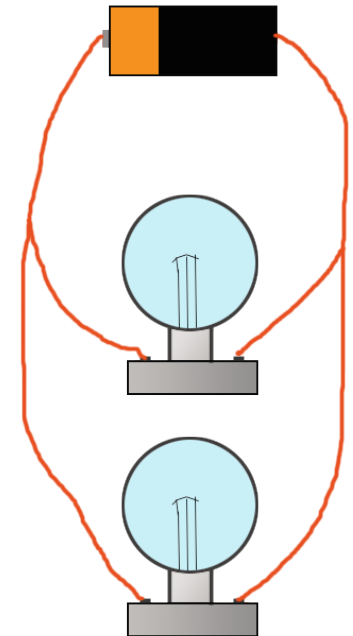

Electrical Circuits

Closed vs. open circuits

- **Circuit** – combines source voltage, a load, and connecting wire to make a path of current flow
- **Closed circuit** – circuit is complete and current can flow from source to the load and return to the source; work can be done
- **Open circuit** – current path is broken or interrupted and no current can flow; work cannot be done

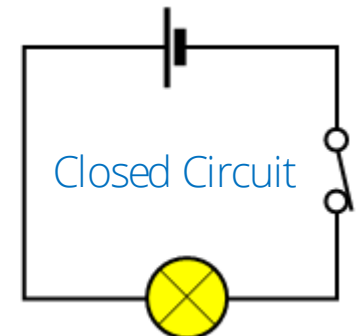
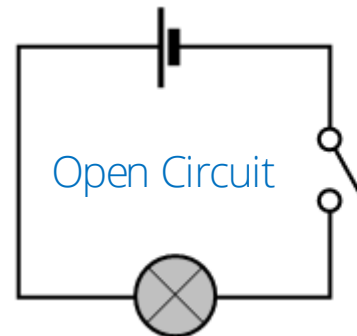

Electrical Circuits

Source voltage

- Source voltage = supply voltage wired to the cooling or heating appliance
- Typically:
 - 120 VAC for gas heating
 - 240 VAC for air conditioners, air handlers, & heat pumps



120 VAC



240 VAC

Electrical Circuits

Source voltage – 120 Volt circuits

From home electrical panel, where either fuses or circuit breakers are installed:

- Three wires to the receptacle:
 - Black wire is “hot” and attached to the load side of the fuse or circuit breaker
 - White wire is attached to neutral terminal buss in service panel
 - Green wire is ground – attach to ground terminal buss in home service panel
- At the receptacle, attach the wires accordingly
 - Black (hot) attached to the short vertical terminal of the receptacle
 - White (neutral) attached to long vertical terminal of the receptacle
 - Green (ground) attached to green ground screw (bottom, round hole in 15 amp receptacle)

Electrical Circuits

Source voltage – 240 Volt circuits

Three wires run from home electric panel to 240 volt service panel for the air conditioning component:

- Red (hot) wire run from L1 side of dual, 240 V circuit breaker
- Black (hot) wire run from L2 side of dual, 240 V circuit breaker
- Green (ground) wire run from ground terminal buss

At service disconnect panel for the 240 VAC air conditioning components, the opposite ends of the three wires are wired:

- Red (hot) wire attached to L1 line side of disconnect switch
- Black (hot) wire attached to L2 line side of disconnect switch
- Green (ground) wire attached to ground lug in service disconnect panel

Electrical Circuits

Series circuits

- One current path
- Often used to control one or more loads by wiring switches or controls in series with loads
- This diagram shows a typical series circuit with two switches wired in series controlling the load
 - If either switch opens, current path will be interrupted; circuit will be de-energized

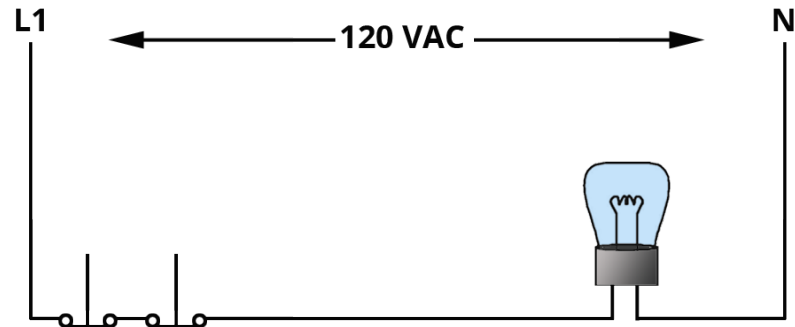

Series Switches Controlling One Load

Electrical Circuits

Series circuits, cont.

- Two or more loads can be wired in series
- Both loads share total supply voltage, based on resistance of each load
- If resistance in each load is the same, voltage is divided equally
- If resistance of one load is higher than resistance of the second load, the load with higher resistance will receive higher voltage across that load

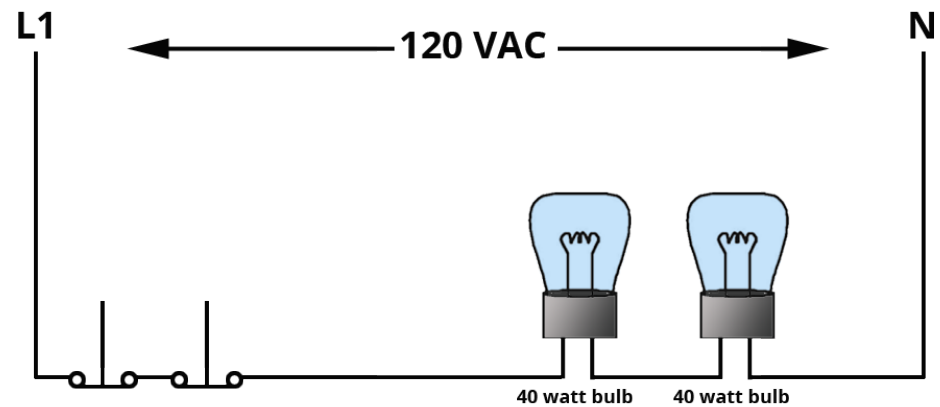

Series Loads of Equal Wattage and Resistance

Electrical Circuits

Rules for series circuits

When 2 or more resistive loads are wired in series, “rules to remember” are:

1. Current remains the same throughout the series circuit
2. Voltage will be divided in proportion to the resistance of each load
3. If any of the series loads fails (opens), all loads will stop working
4. Total resistance of the series circuit is the sum of all resistances in the series circuit
5. Sum of the voltage drops across each resistive load is equal to applied or source voltage

Electrical Circuits

Calculating current, resistance, & voltage in a series circuit

- In this diagram: 3 resistive heaters wired in series
- Each has a different resistance value
- When voltage is applied, voltage will be divided in proportion to resistance
- Amount of voltage across each will be different
- Voltage referred to as voltage drop
- Each heater consuming part of the voltage causes a voltage drop to the other heaters

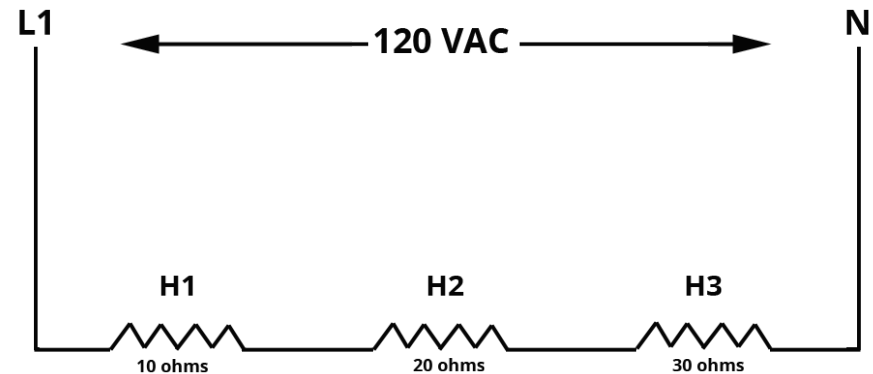

Series Loads of Unequal Values

Electrical Circuits

Calculating current, resistance, & voltage in a series circuit, cont.

Calculate voltage drops across each heater:

1. Use Ohm's Law: $E = I \times R$
2. Total resistance found by adding:
 $R_1 + R_2 + R_3 = R_T$
3. Substituting values:
 $10 + 20 + 30 = 60$ ohms
4. To determine current flow, use Ohm's Law again. Solve for current:

$$I = E / R$$

5. Using the formula:

$$I = 120/60 = 2$$

6. Now have total current; find voltage drop across each resistance using:

$$E = I \times R$$

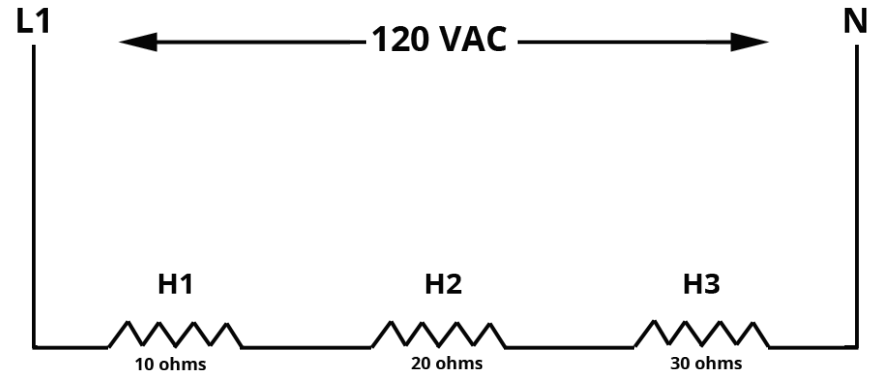

Series Loads of Unequal Values

Electrical Circuits

Calculating current, resistance, & voltage in a series circuit, cont.

6. Voltage drop across H1:

$$E_H = I \times R_{H1}$$

7. Substituting:

$$E_{H1} = 2 \times 10 = 20 \text{ volts}$$

8. Doing the same for H2 and H3:

$$E_{H2} = 2 \times 20 = 40 \text{ volts}$$

$$E_{H3} = 2 \times 30 = 60 \text{ volts}$$

9. Add voltage drops, Rule 5 applies:

$$20 + 40 + 60 = 120$$

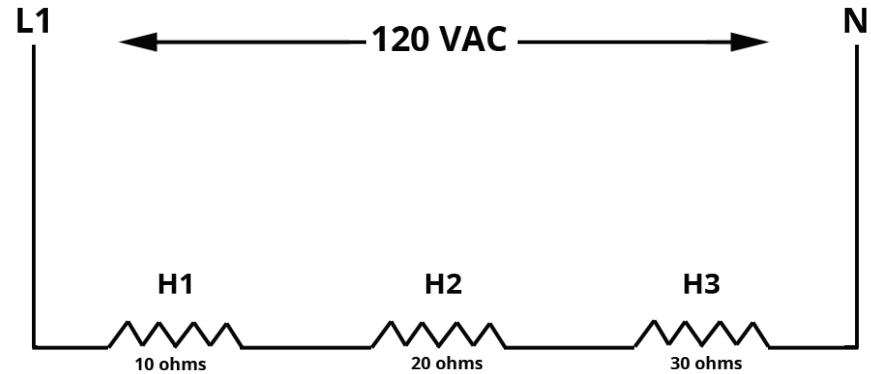

Series Loads of Unequal Values

Electrical Circuits

Parallel circuits

- More than one current path
- Most electrical components in heating or cooling products are arranged in parallel so each component receives source voltage
- In this example, both loads receive the source voltage of 120 VAC
- Total amperage is the sum of amps in each load circuit

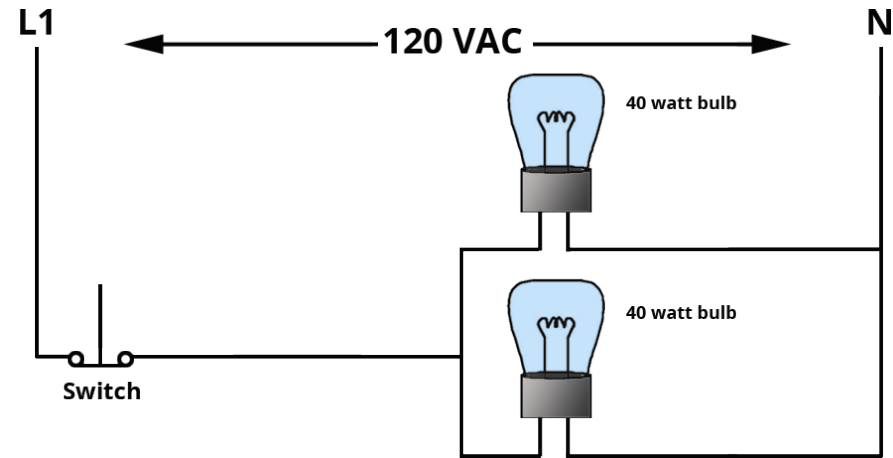

Parallel Circuit – Two Loads

Electrical Circuits

Rules for parallel circuits

When 2 or more resistive or inductive loads are wired in parallel, “rules to remember” are:

1. All loads receive full line voltage (source voltage)
2. The total amperes in the circuit are the sum of the individual amperes measured in each branch of the parallel circuits
3. Each load operates independently of the others; if one load fails, the others will continue to work
4. Total resistance of all branches in parallel is less than the smallest branch's resistance (total resistance is less than the least)

Electrical Circuits

Calculating resistance in a parallel circuit

- Calculating voltage is not necessary
- Amperes – determined by applied voltage divided by loads' resistance; total amperes = sum of amperes measured in each branch
- Only element requiring calculation is total resistance
- As resistances are added in parallel, total resistance decreases
- Formula for determining total resistance of two resistances in parallel:

$$R_T = \frac{R_1 \times R_2}{R_1 + R_2}$$

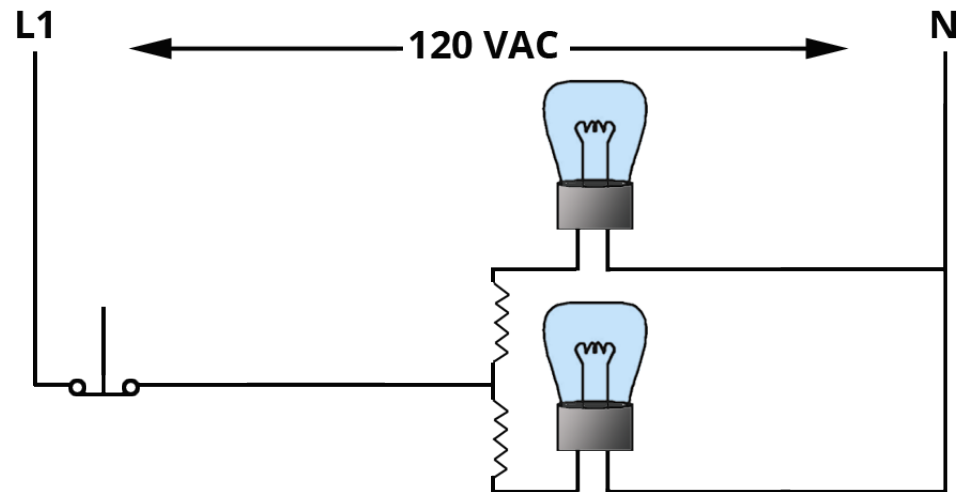

Electrical Circuits

Calculating resistance in a parallel circuit, cont.

- When more than two resistances are in parallel, another formula applies:

$$R_T = 1/R_1 + 1/R_2 + 1/R_3$$

- When adding reciprocals, you must find a common denominator and convert.
- Invert and divide new fraction to get total resistance.

Example 1:

Find total resistance in this diagram

- Only 2 resistances, so use the formula

$$R_T = \frac{R_1 \times R_2}{R_1 + R_2}$$

- Substitute values in the formula:

$$R_T = \frac{30 \times 45}{30 + 45}$$

$$= \frac{1350}{75} = 18$$

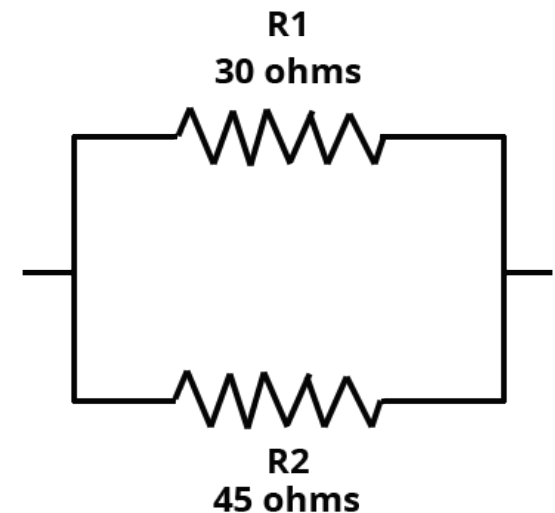

Electrical Circuits

Calculating resistance in a parallel circuit, cont.

Example 2:

Find total resistance in this diagram

1. Use the formula of reciprocals:

$$R_T = 1/R_1 + 1/R_2 + 1/R_3$$

2. Substitute values in the formula:

$$R_T = 1/6 + 1/12 + 1/24$$

3. Find common denominator = 24

4. Convert:

$$\begin{aligned} R_T &= 4/24 + 2/24 + 1/24 \\ &= 7/24 \end{aligned}$$

5. Invert and divide:

$$= 24/7$$

6. Total resistance $R_T = 3.428$

